

Type: OWST-70				Part No. OWST7021 ...		
Part No.	Installation Length L (mm)	Extension Length D (mm)	* Load per pair (kg)	DRILLING TABLE		
				Dimension A	Dimension B	Dimension C
OWST7021.040	400	400	500	50	---	200
OWST7021.045	450	450	490	50	---	250
OWST7021.050	500	500	480	50	---	300
OWST7021.055	550	550	470	50	---	350
OWST7021.060	600	600	460	50	---	400
OWST7021.065	650	650	450	50	200	---
OWST7021.070	700	700	440	50	225	---
OWST7021.075	750	750	440	50	250	---
OWST7021.080	800	800	420	50	275	---
OWST7021.085	850	850	410	50	300	---
OWST7021.090	900	900	400	50	325	---
OWST7021.095	950	950	390	50	350	---
OWST7021.100	1000	1000	380	50	375	---
OWST7021.105	1050	1050	370	50	400	---
OWST7021.110	1100	1100	360	50	425	---
OWST7021.115	1150	1150	350	50	450	---
OWST7021.120	1200	1200	340	50	475	---
OWST7021.125	1250	1250	330	50	500	---
OWST7021.130	1300	1300	320	50	525	---
OWST7021.135	1350	1350	310	50	550	---
OWST7021.140	1400	1400	300	50	575	---
OWST7021.145	1450	1450	290	50	600	---
OWST7021.150	1500	1500	280	50	625	---
OWST7021.155	1550	1550	270	50	650	---
OWST7021.160	1600	1600	260	50	675	---
OWST7021.165	1650	1650	250	50	700	---
OWST7021.170	1700	1700	240	100	650	---
OWST7021.175	1750	1750	230	100	675	---
OWST7021.180	1800	1800	220	100	700	---
OWST7021.185	1850	1850	210	100	725	---
OWST7021.190	1900	1900	200	100	750	---
OWST7021.195	1950	1950	190	100	775	---
OWST7021.200	2000	2000	180	100	800	---

\* The maximum safe load is given for a fully extended pair of slides, mounted on the major axis, with a load spread uniformly along the inner beam

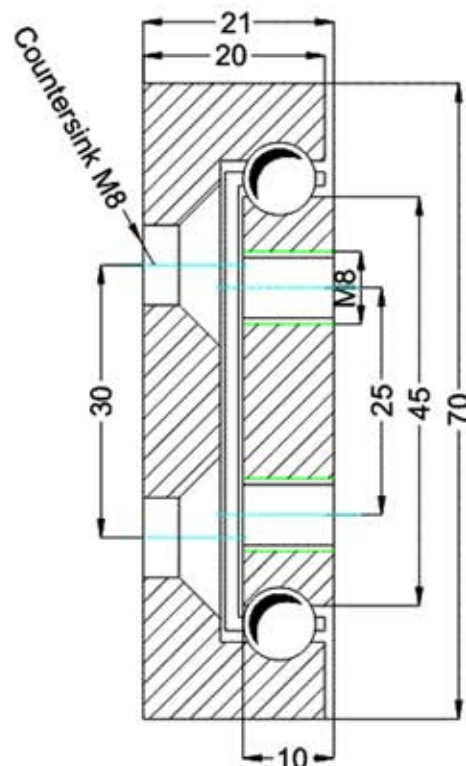

WE RECOMMEND USE ON THE MAJOR AXIS  
DO NOT DISMANTLE THE SLIDE!!!

**Options:**

Various dimensions of the main profile, optional slide lengths, extensions, drillings, diameters and hole centers to customer's requirement.